



BUTLER® BUILDING GUIDE



TABLE OF CONTENTS

ORDERING PROCESS	
3 Step Order Process	1
Drawing Guide with Options	2
The Butler Difference	3
STRUCTURAL SYSTEMS	
Widespan™ Structural System	4
Landmark™ 2000 Structural System	5
Conventional/Hybrid Structural	6
Hardwall Structural System	7
Multi-Story Structural System	7
ROOF SYSTEMS	
MR-24® Roof System	8
CMR-24® Roof System	10
ThermaLiner™ Insulation System	11
TBS™ Insulation System	11
VSR II™ Architectural Roof System	11
Butlerib® II Roof System	12
Reroof Solutions	13
SunLite Strip® Daylighting System	13
Sky-Web® Fall Protection Systems	13
WALL SYSTEMS	
StylWall® II Wall System	14
eStylWall™ II Wall System	14
ShadowWall™ Wall System	15
EX Wall Systems	15
Butlerib® II Wall System	15
TextureWall™ Panel Wall System	16
Butler Thermawall™ Wall System	17
PAINTING TRIM AND PANELS	
Roof Colors	18
Wall and Trim Colors	19
Color Reflectance	20
BUILDING SYSTEMS	
Complex Building Designs	21
Classic Building Systems	22
Self-Storage Building System	22
BUILDING GREEN	
A Commitment to Building Green	23
“Cool Roof” Finishes	24
Butler-Cote™ Finish System	24
BUILD WITH CONFIDENCE	
Research Center	25
Butler Certified Erection	26
Design Integrity	26



Ordering Process

Metal Building Sales® offers a complete design-build solution. One single reliable source for every aspect of construction including planning, building, permit approval, and service. As your on-site project manager, Metal Building Sales® communicates quicker, more precisely, eliminating extra steps, condensing timelines, and ultimately adding to your bottom line. Never sacrificing quality, we have some of the best engineering and fabrication times possible in the industry. Almost always are plans approved by building departments with no comments just based on our extraordinary reputation. In designing your new Butler® Building, there are virtually unlimited options regarding appearance and functionality. Metal Building Sales® assures every component of your new building is designed, engineered, and manufactured to the exact specifications expected. Our value engineering creates fast assemblies and long-term performance.



The first step to order your new Butler Building would be to set up a person-to-person conference about your new building. This can easily be done by sending us a quote request telling us the size of your building. At that initial meeting, Metal Building Sales® will help design and educate you on all of the particular product systems and accessories we carry leading to a complete and specified design.

The second step will be to approve your custom quote made especially for your job site and specifications which can include foundations, installation, roll-up doors, and general contracting services. The Unit Summary Report will outline your order providing building safety codes and loads required for the manufacturing and engineering of your new Butler Building.

The last step will be to review the engineered plans and calculations releasing your building for fabrication. Your new Butler® Building is a custom design meant only for your job site and will be shipped factory direct to you in as little time as 8 to 10 weeks pending current work load.



SKETCH YOUR BUILDING

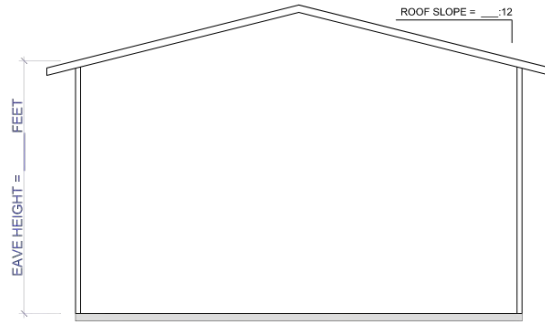

SCHEMATI BUILDING DESIGN:

- 1) Please fill in your Building Dimesions, L X W X H
- 2) What kind of Roof Slope (3:12 Shown)
- 3) Do you want eave overhangs at sides
- 4) Draw your Roll-Up Door Locations and Sizes
- 4) Show us where you want Personelle Doors
- 5) Show us where you want windows
- 6) Do you want any Wall Louvers or Ridge Vents
- 7) Show us where you want Skylights (LTP's)
- 8) Draw in Any Other Needs you have or describe
- 9) Choose your roof and wall panels
- 10) Do you want Gutters and Downspouts

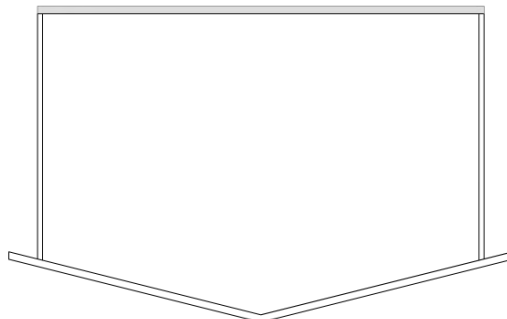
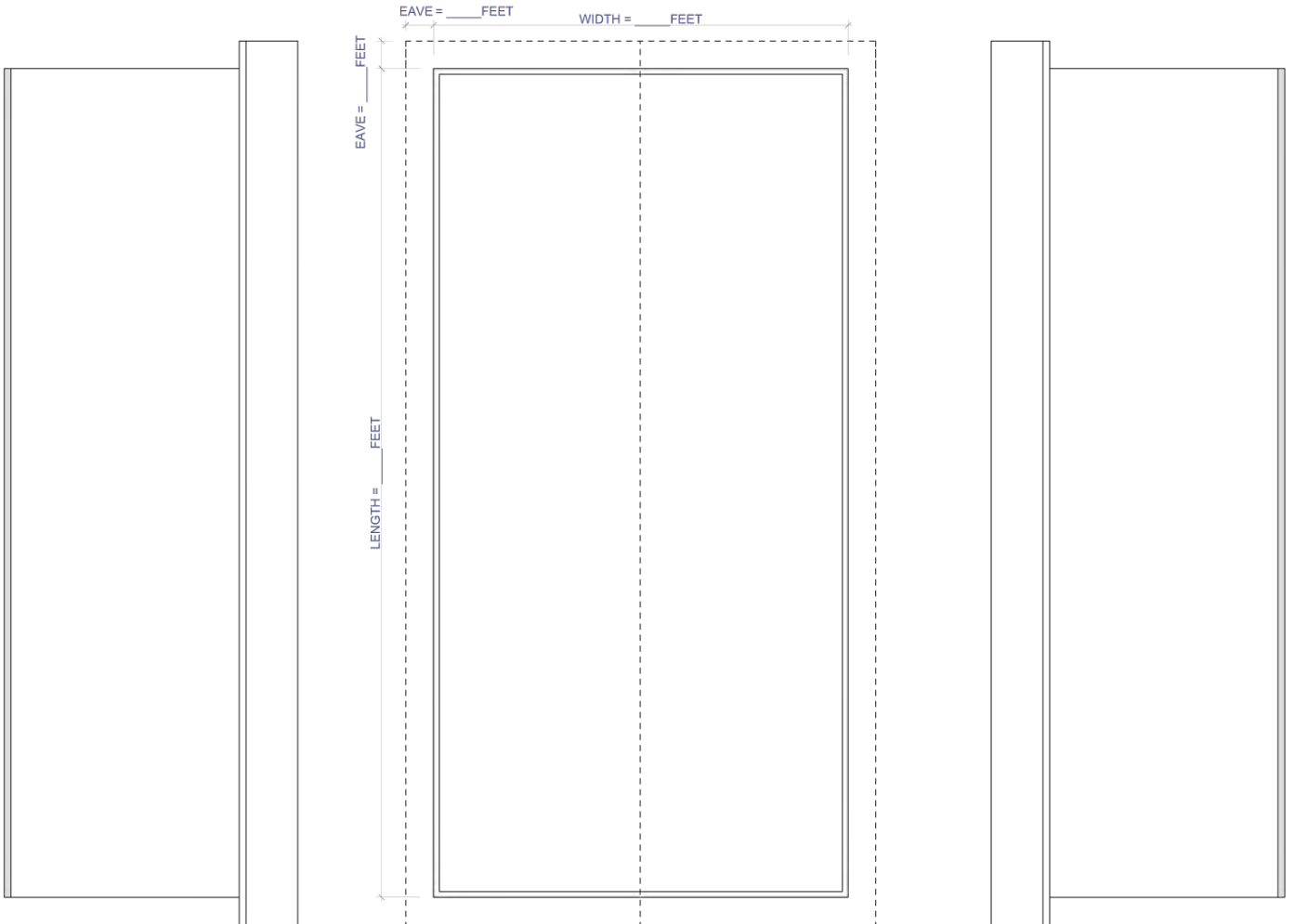



Building a Business Advantage

Successful manufacturer attracts five applicants per day with help of new building.

Building a Business Advantage

Since 1901, Butler Manufacturing™ provides the industry's most innovative steel building system.

The Butler Builder®

Look to **Metal Building Sales®** for the best Butler® has to offer in manufacturing, design, and construction services.

Built to Last

Our building systems are engineered to exact specifications for higher quality installation and better building performance.

Lifetime Savings

Our building assemblies are tested and proven to be more energy-efficient than industry standards.

The Butler Difference

You'll often hear us refer to our unique product advantages as "The Butler Difference." We invite you to discover what this difference can mean for you.

Butler Builders

With superior knowledge of construction, these independent building professionals offer single-source responsibility and complete construction services. Today there are more than 1,000 Butler Builders worldwide—the largest network of construction professionals in the world.

MR-24® roof system

It's the most specified standing-seam roof system on the market, with more than 3 billion square feet installed worldwide. The MR-24® roof system has unique design features that accommodate roof movement under temperature swings and virtually eliminate roof leaks.

Factory-punching

Only Butler offers factory-punched secondary structural members to assure a precision fit on the jobsite. This helps to speed installation, lower construction costs, and create low-maintenance structures for greater lifecycle cost savings.

High-performance products

With products such as acrylic-coated galvanized C/Z purlins and girts, as well as systems that integrate easily with conventional building materials, Butler provides innovative solutions that enhance performance and add value.

Butler-Cote™ finish

Butler offers a superior Kynar 500® or Hylar 5000® finish system as the standard exterior finish on all painted panels and trim. This incredibly durable coating is the finest finish in the industry.

Industry-leading warranties

Our multi-year warranties protect your investment. Available 25-year weathertightness warranties are a testament to the performance that a Butler® building system offers.





Widespan™ Structural System

A structural system should enhance a building's functionality, not stand in its way. That's the principle upon which the Widespan™ structural system is designed. This versatile rigid frame system assures maximum use of interior space, while also providing virtually unlimited flexibility with regard to building width, height, roof slope, and exterior finish. And Butler's precision engineered system adds speed for cost savings in construction.

The Widespan system offers extensive framing options with these benefits:

- Large areas of uninterrupted space
- Straight or tapered columns
- Minimal or no interior columns to optimize building costs and enhance functionality
- Extensions and expansions for future building requirements are easily accommodated
- Acrylic-coated galvanized secondary structural members for better appearance and durability

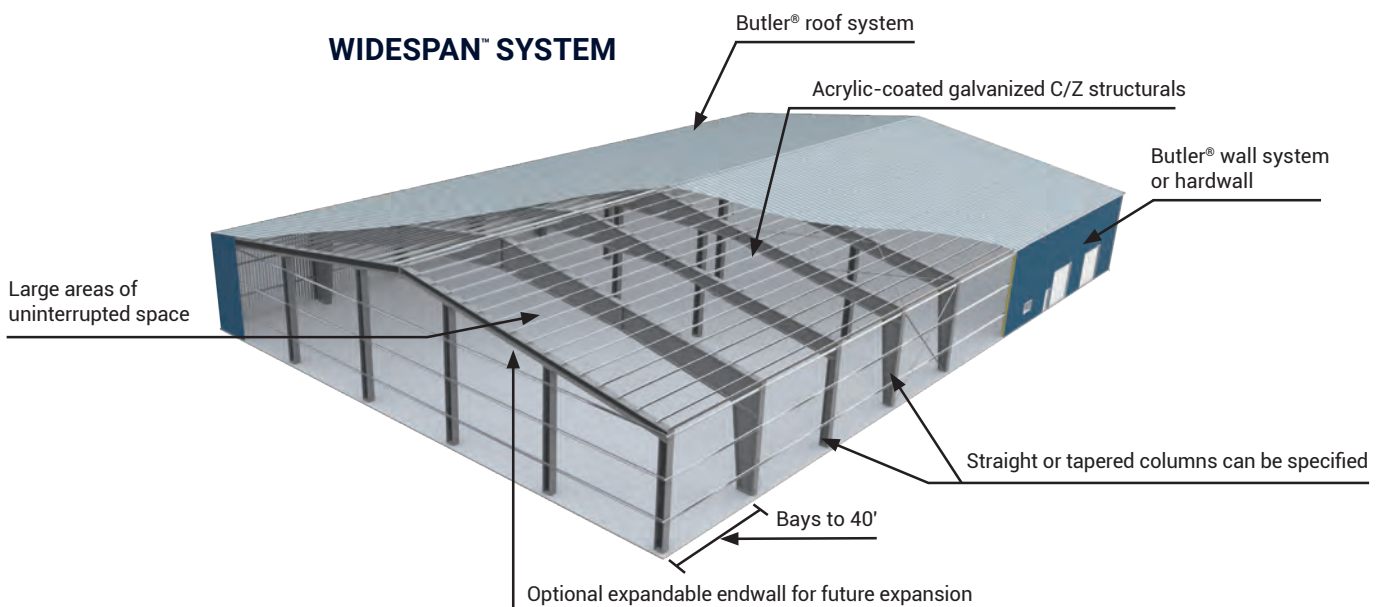

PROVEN BUILDING QUALITY



Landmark 2000™ Structural System

If large interior space and extra-long bay sizes are important to your building's functionality, then the Landmark 2000™ structural system is the right choice. The Landmark 2000 system combines solid-web primary frames and factory-punched Truss Purlin_{XT}™ secondary structural members to form a long-bay framing system that can span up to 60 feet.

- Uses Truss Purlin_{XT}™ to achieve up to 60-foot bays, available in 30-, 34- and 40- inch depths
- Features acrylic-coated galvanized trusses, which protect against corrosion and provide an attractive interior appearance
- Enhances ease of erection through factory-assembled, factory-punched structural members
- Offers design flexibility for a combination of roof slopes
- Integrates with conventional wall products, such as masonry, precast concrete and site-cast tilt wall

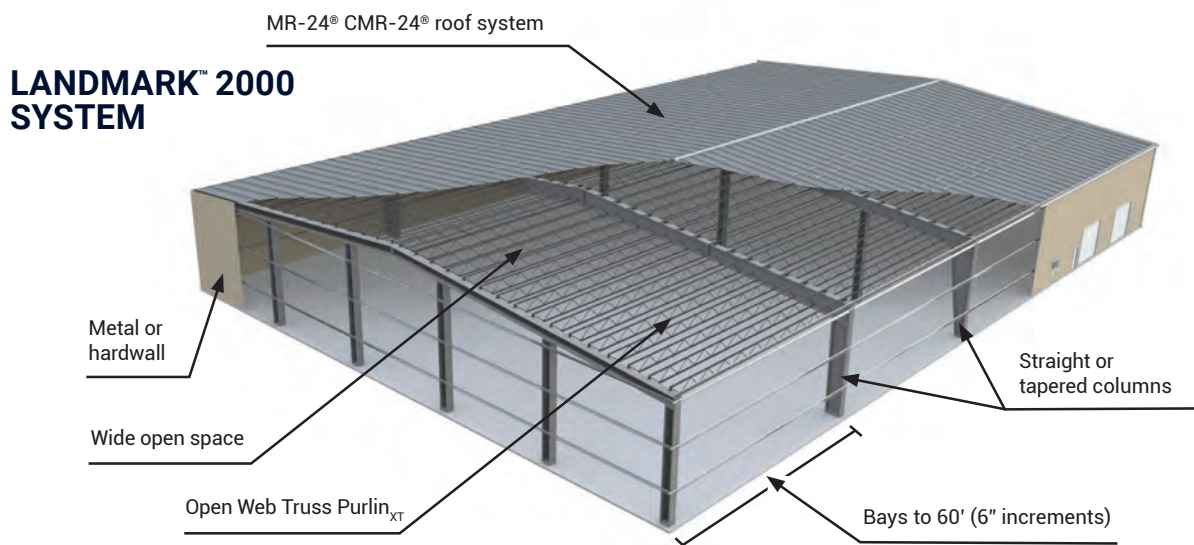

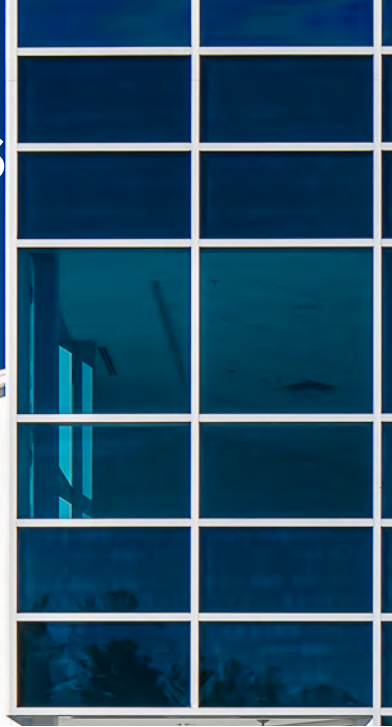

Conventional/Hybrid Structural System

Conventional or Hybrid building designs come in any shape or size to meet the demands for any project. Butler conventional buildings offer the same flexibility found with traditional construction, while using a systems construction approach to deliver a cost-effective, high performance building for a myriad of building end-uses.

- Able to integrate conventional steel such as mill beams and truss girders with Butler secondaries or truss purlins, where appropriate, for economical solutions
- Includes structural designs for mezzanine and multistory applications to maximize space
- Offers unlimited flexibility to use conventional exteriors such as masonry, EIFS or concrete
- Accommodates membrane and built-up roofing systems using structural metal deck



Finding Better Answers

Pioneering Innovations

Our innovations help you build better, through more flexible and durable building systems and technology that streamline the building process.

Dedicated To Research And Development

We constantly push the boundaries to find better answers to building challenges.

Expertise And Accountability At Every Step

You'll have a single point of contact dedicated to exceeding expectations in the most efficient way possible. Their deep knowledge and expertise will help you foresee challenges and deliver better solutions.

YOU HAVE IDEAS. WE HAVE SOLUTIONS.

Hardwall Structural System

The Butler Hardwall system combines conventionally built walls with Butler® structural and roof systems. The hardwall system is designed for load-bearing masonry or concrete wall projects.

- Integrates with the industry's finest standing-seam roof system—the MR 24® roof system
- Provides the opportunity to create traditional flat appearance roof lines by easily integrating with any type of conventionally built walls
- Offers unlimited design flexibility, as well as fast assembly

HARDWALL SYSTEM

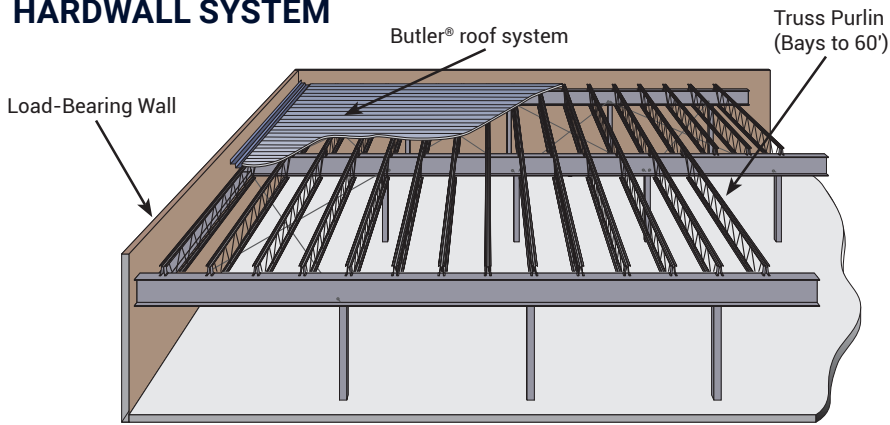

Multi-Story Structural System

The Multi-Story structural system offers the same benefits of our low-rise building expertise in buildings with two or more stories. The system utilizes the combined technologies of conventional and systems construction to create a cost-effective, high-performance building.

- A single-source solution that provides value, convenience, and architectural enhancement
- Available with a variety of roof and wall options, including any Butler standing-seam roof system
- Exterior finishes including brick, block, curtain wall, and metal wall panels
- Surprising building applications with all the traditional performance benefits of Butler



Roof Systems

MR-24[®] Roof System

Whether you're tired of dealing with costly roof repairs or you simply want to avoid them from the outset, you'll find the ideal solution in the MR-24[®] roof system by Butler—the industry's most specified standing-seam metal roof system.

Proprietary technologies have established the MR-24 roof system as the recognized standard in the industry. It acts like a monolithic steel surface covering your entire building, providing superior protection for the inventories, assets, and lives inside.

More than 3 billion square feet of the MR-24 roof system have been installed since 1969, and life cycles of over 50 years have been achieved. It's a testament to the unmatched protection it provides.

It stands to reason that the industry's best roof also offers the industry's best warranty. The MR-24 roof system is available with a 25-year weathertightness warranty. Ask your Butler Builder[®] for details.

This seaming process uses a heavy-duty four-stand, electric, portable roll-forming machine called the Roof Runner.



Our unique MR-24 roof system combines design with functionality to be energy efficient and reliable.

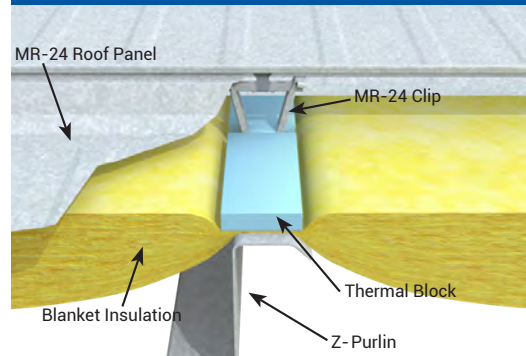

BUTLER ROOFS ARE WEATHERTIGHT, LOW-MAINTENANCE AND WORRY-FREE

Moveable Roof Clip

The MR-24 clip (below) allows the roof to expand and contract with changing temperatures. This mobility prevents stress at the clips, fasteners, and panel splice that could otherwise make the building vulnerable to leaks and wind damage.

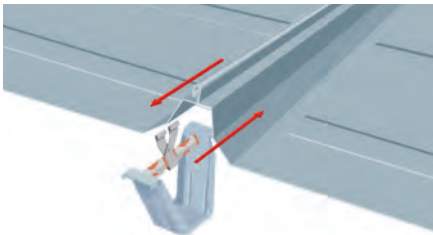

The Pittsburgh Double-Lock Seam

Only the MR-24® roof system seams are mechanically field-rolled 180 degrees to complete a 360-degree Pittsburgh double-lock seam. Other manufacturers simply crimp or snap the seams into place, forming a loose, vulnerable seal.

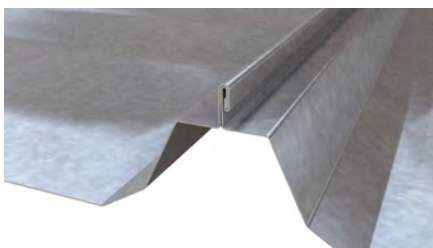

Perfect Alignment

All roof panels and structural members of the MR-24 roof system are factory-punched to assure proper alignment and weathertightness, as well as the accurate installation of closures, roof accessories, and trim.

Staggered Panel Splices

Locating panel splices at the same position across the roof makes it almost impossible to seal and protect against leaks. The MR-24 roof system eliminates this problem with staggered panel splices. All splices are also located over supporting steel to reinforce vulnerable areas, as opposed to midair splices common with other manufacturers.

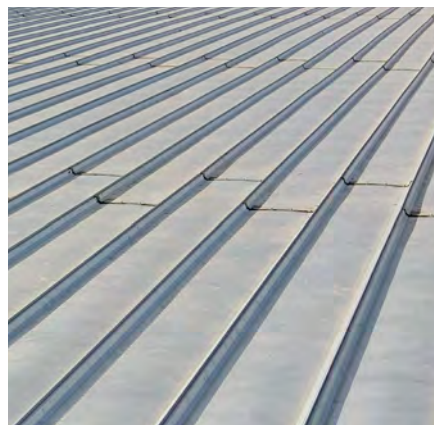

Energy Savings

Because the MR-24 roof system is metal and moves freely with the forces of expansion and contraction, additional insulation thicknesses will not cause roof deterioration as commonly happens with conventional built-up roofs. A variety of tested insulation systems are available. For information about our energy saving "cool roof" finishes see page 21.

Wind Uplift Resistance

The MR-24 roof system carries the highest UL wind uplift rating (Class 90). It has also been approved by FM Global as a Class 1 Panel roof, which may help lower your insurance costs. In addition, the MR-24 roof system is approved for use under the strictest codes, including Miami-Dade County, Florida.



Roof Systems



CMR-24[®] Roof System

The CMR-24[®] roof system offers all the benefits of the MR-24[®] roof system with a layer of Thermax[™] rigid insulation board and an interior steel liner. This liner gives the interior a finished look while protecting the roof's insulation and providing excellent energy savings.

- Excellent energy efficiency with a tested U-factor of .037 or an effective R-value of R-27
- Uses the MR-24 panel clip to allow movement during roof expansion and contraction
- Incorporates the MR-24 Pittsburgh double-lock seam to ensure weathertight performance
- Available 25-year weathertightness warranty
- Thermax metal building board insulation is tested and listed for fire resistance by UL
- Painted or unpainted metal liner is available
- Available "cool roof" finish options

CMR-24 ROOF SYSTEM APPLICATIONS

- Retail
- Warehouses
- Manufacturing plants
- Gymnasiums
- Airplane hangars
- Other larger structures

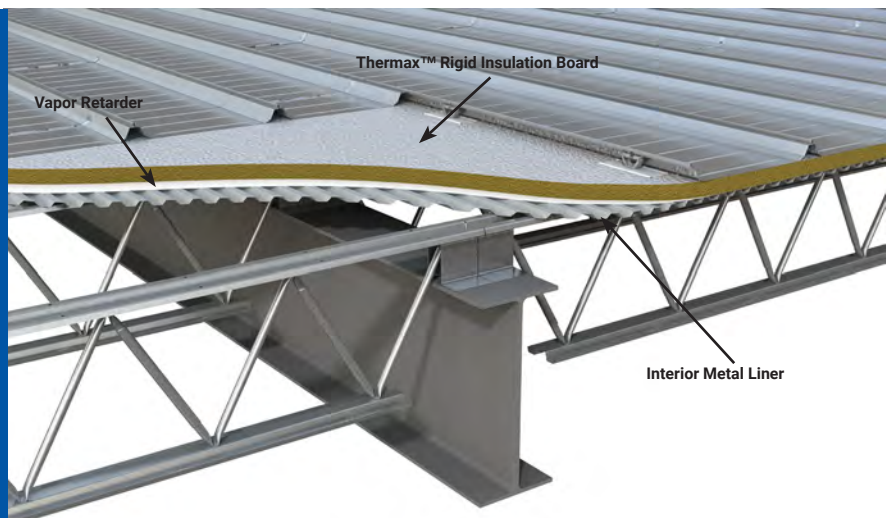

The acoustic characteristics of rigid foam board insulation may not be suitable for certain buildings. See your Butler Builder[®] for more information.

ENGINEERED FOR PERFORMANCE



ThermaLiner™ Insulation System

The state-of-the-art ThermaLiner™ insulation system incorporates all the benefits of the MR-24®, VSR II™, or Butlerib® II roof systems, with the additional advantages of superior thermal efficiency, condensation control, and noise reduction. The roof system is available as painted or unpainted Galvalume®.

- Superior energy efficiency can be achieved up to a tested U-factor of .026 or an effective R-value of R-38.7
- Self-drilling screws speed installation
- Can be installed on Landmark 2000™ or Widespan™ structural system

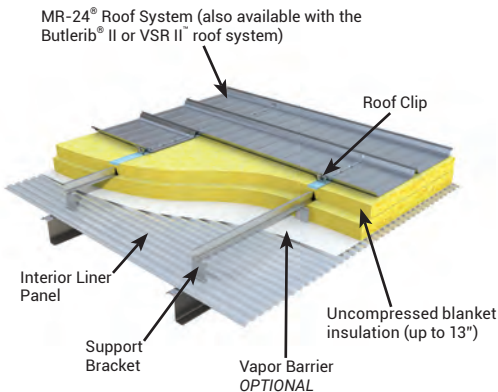

TBS™ Insulation System

As energy codes become more stringent and energy costs continue to fluctuate, it's important to have an insulation system that will help save on your building's heating and cooling costs. The unique design of the TBS insulation system for the MR-24® roof system provides more blanket insulation to meet stringent U-factors and R-values required by stricter energy codes. It also can be installed in a fraction of the time it takes to install competitive below-the-purlin insulation systems.

- Meets IECC 2018 codes with tested U-factors as low as 0.029
- Roof structurals are accessible as a result of above the purlin system installation
- Sky-Web® and Sky-Web II® fall protection and insulation support system compatible

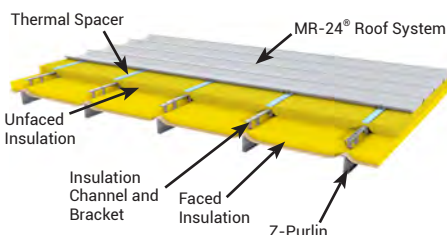

VSR II™ Architectural Roof System

The VSR II™ roof system is a versatile standing-seam roof developed specifically for architectural applications. Designed to easily accommodate complex roof geometries, the VSR II roof panels can be applied to light-gauge steel framing or any properly designed roof deck on roof slopes of 1/4:12 and greater.

- Has minor longitudinal flutes that provide a pleasing appearance
- Made with the low-gloss, high-quality Butler-Cote™ finish system
- Available in a variety of visually appealing "cool roof" colors
- Approved by FM Global
- Has UL Class 90 wind uplift rating

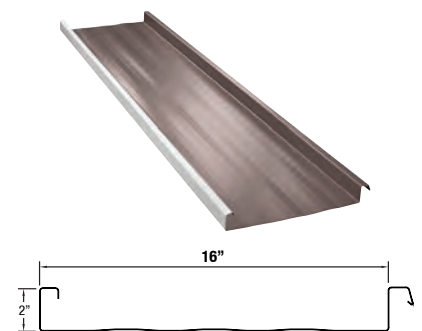



Roof Systems

Butlerib® II Roof System

A building's roof system is no place to compromise quality and protection—particularly on projects with heightened budgetary constraints. The Butlerib® II roof system is engineered to provide the ideal option in such instances, offering low installation and maintenance costs with the assurance of an available 10-year weathertightness warranty.

- The best thru-fastened roof system available in the industry
- Exclusive Lock-Rivet™ fastener doesn't work loose over time
- Special sealant groove assures proper application of the sealant
- Factory-slotted holes allow for thermal expansion and contraction of panels
- Deep 1-1/2-inch corrugation and "return leg" add strength and support

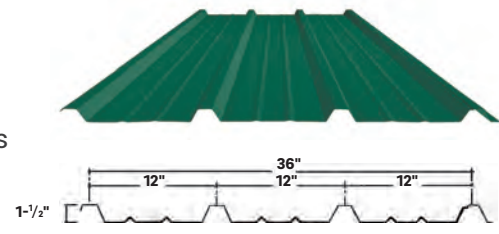

Corrugations standing 1-1/2" high provide extreme durability while offering an attractive appearance

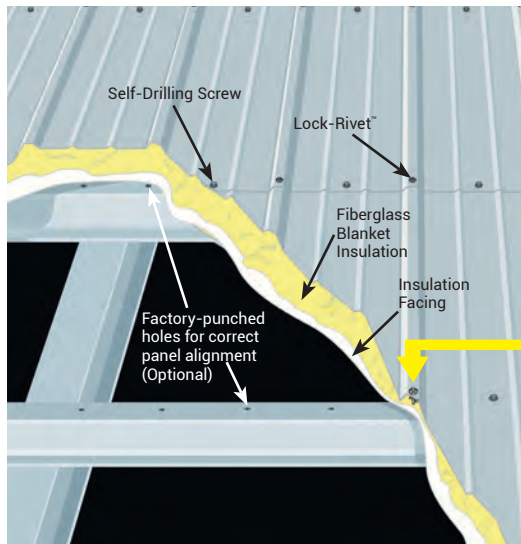

Why the Butlerib® II Roof System Beats the Competition

To provide added support against roof traffic, Butlerib® II roof panels incorporate a return leg on all sidelap connections.

Butler Method

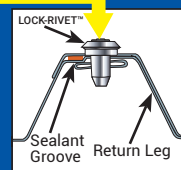

Other Manufacturers

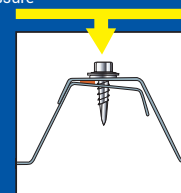
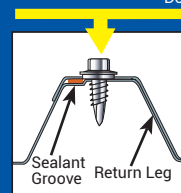

Downward Pressure

ROOF SYSTEMS THAT ARE BUILT TO LAST

ReRoof Solutions

Butler offers several reroof options that enable you to address potentially devastating roof problems with an affordable, long-term solution. In most cases, these systems can be installed over an existing roof, avoiding interruptions to your daily business activity.

- **Retrofit Metal-Over-Metal Systems** allow the MR-24® roof system or the VSR II™ architectural roof system to be installed over an existing metal roof
- **The Slope Build-up Reroof System** is designed for application over flat built-up or membrane roofs

A Butler reroof system offers a recyclable, low maintenance and long-life roof solution that will enhance the energy efficiency of your building.

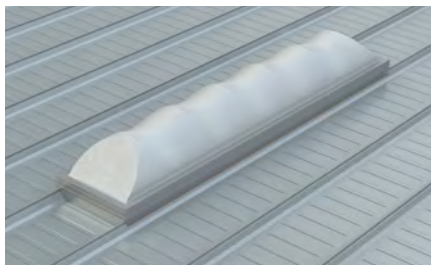

SunLite Strip® Daylighting System

The self-curbing SunLite Strip® daylighting system adds natural daylight, occupant comfort and energy-savings to any Butler building featuring the MR-24® standing seam metal roof system. Installed in one-third the time of industry standard curb-mounted systems, this unique SunLite Strip design can reduce roof penetrations by 30% while also preserving the MR-24 roof system's weathertight integrity.

- Reduces electric lighting costs by up to 70% when combined with lighting controls
- Prismatic polycarbonate domed technology adds up to 3 times the amount of light earlier and later in the day vs. translucent panels

- Prismatic lenses provide 100% diffused light to eliminate hotspots and glare
- Helps owners take advantage of federal tax deductions
- Can provide a return on Investment in 3 to 5 years

Sky-Web® Fall Protection and Insulation Support Systems

The Sky-Web® and Sky-Web II® systems protect workers from falls and certain objects that may be dropped during roof construction. The innovative mesh systems remain in place to act as an insulation support after the building is complete.



Sky-Web® and Sky-Web II® do not eliminate fall hazard from the non-leading-edge perimeter of the roof during installation.



Wall Systems



StylWall® II Fluted Wall System

The ribbed design of the StylWall® II Fluted panels provides a rich appearance in new or retrofit uses.

- Concealed fasteners add to vertical appearance
- Fluted panels accommodate a variety of insulation systems
- Can be combined with other conventional wall materials such as brick and glass

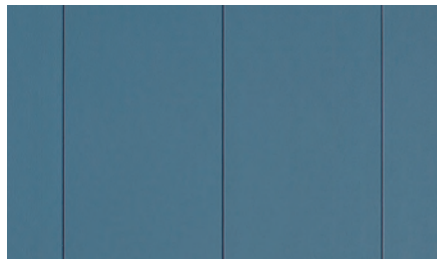
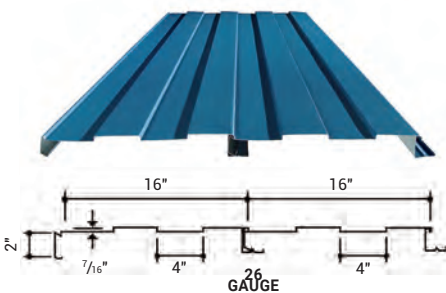

StylWall® II Flat Wall System

StylWall® II Flat wall panels feature an outside embossed surface. Each panel is fastened to the wall structural system and then “locked” into the adjacent panel, concealing the fasteners and enhancing the building’s appearance.

- Rigid insulation board improves the insulating properties of the wall and the flatness of the metal face
- Conventional finishing materials can be easily fastened to the interior

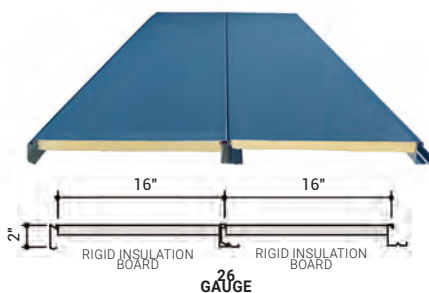

eStylWall™ II Flat or Fluted Wall System

The eStylWall™ II Flat or Fluted wall system is an energy efficient solution with appealing visual interest for any project. Combining the aesthetic benefits of the StylWall® II wall panel with a patented thermal spacer block design delivers superior energy efficiency.

- Fluted panel enables thicker layers of insulation to achieve an enhanced thermal performance

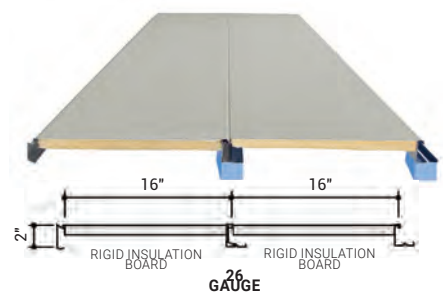

WE HAVE MULTIPLE WALL DESIGNS TO FIT YOUR REQUIREMENTS

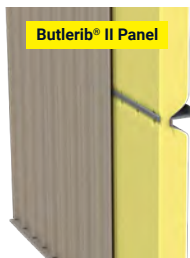

EX Wall Systems

The Butlerib II EX™ Wall System and the Shadowall EX™ Wall System address the challenges of ever-changing energy codes while providing a competitive alternative to insulated metal panels. A unique stanchion design addresses new energy codes requiring a maximum U-factor by creating a larger insulation cavity between the structural and the wall panel.

- Accommodates 8-inches of blanket insulation using a single-skin wall panel to improve thermal performance
- Achieves U-factor rating between 0.46 and 0.47
- Thermal values tested in the accredited Butler Guarded Hot Box that quantifies energy efficiency

Shadowall™ Wall System

The Shadowall™ wall system is ideal for creating architecturally pleasing exteriors, particularly in instances where energy efficiency is a key concern.

- Fasteners are recessed deep in panel corrugation to enhance appearance
- Available factory-punched panels and structurals add speed and accuracy in installation
- Transition pieces assure precision with window and door installation

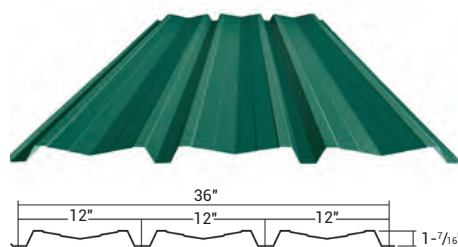

Butlerib® II Wall System

With an attractive combination of quality and affordability, the Butlerib® II wall system remains an extremely popular choice for virtually any type of building application.

- Deep 1-1/2-inch panel corrugations reinforce the building's panel strength
- Available factory punching of panels assures fast and accurate installation

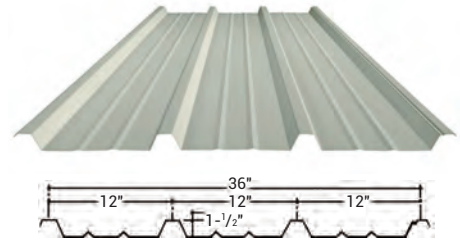



TextureWall™ Panel Wall System

TextureWall™ panels have an exterior textured surface that creates a stunning stucco appearance. The surface is created by the Texture-Cote™ finish system, a hard aggregated, fiber-reinforced polymer finish that resists the effects of impact, abrasion, and weather.

- Satisfies many local building codes requiring masonry or stucco exteriors
- Features a full 10-year warranty on material and application
- Factory-fabricated composite insulated metal panels deliver excellent energy efficiency with effective R-values of R-15.1 to R-29.4 (for a range of panel thicknesses from 2" to 4")
- Factory-applied finish of TextureWall panels allows system to be erected in virtually any weather condition
- Features concealed fasteners and allows simple installation from outside the building envelope



Aspen White II

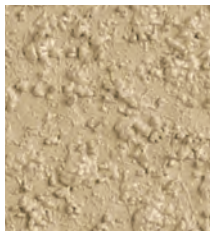

Adobe II



White II

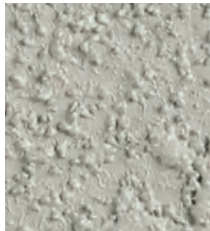

Gray II

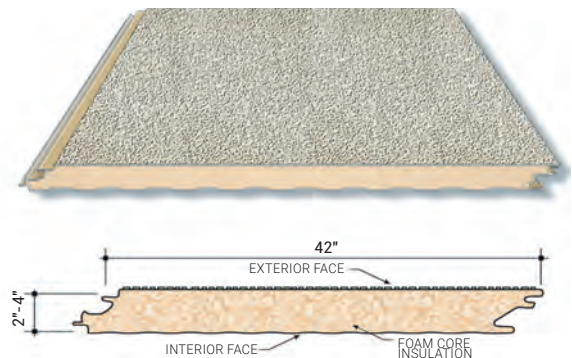

Note: Colors as shown may vary from panel colors due to variations in the printing process. Colors and color availability subject to change without notice.

WE PROVIDE THE FINISHING TOUCHES

Butler Thermawall™ Wall System

The Butler Thermawall™ wall system is a factory-fabricated composite insulated metal wall system with concealed fasteners for a clean, attractive appearance. Panel thicknesses of 2, 2-1/2, 3, and 4 inches are available to match your thermal performance needs, with effective R-values ranging from R-15.1 to R-29.4. The R-value of the polyurethane core used in Butler Thermawall and TextureWall panels is among the highest insulating value (per inch thickness) of any building material available today. The system is UL certified for 1- or 2-hour fire resistance assembly when installed per UL U652.

Fluted Panels

Butler Thermawall™ Fluted panels create an exterior surface with fluted (3/8" deep) corrugations.

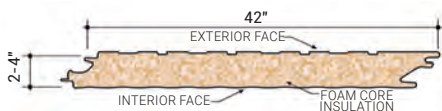
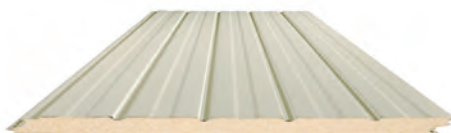

Fineline Panels

Butler Thermawall™ Fineline panels create an exterior surface with fineline (1/8" shallow) corrugations.

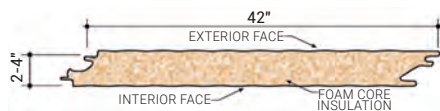

Flat Panels

Butler Thermawall™ flat panels create a smooth, embossed exterior surface.

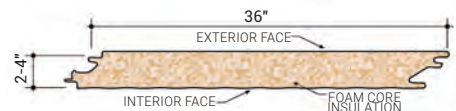
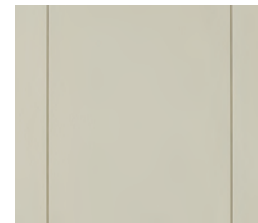

Butler-Cote™ Finish System

for Butler® Building Systems

All Butler-Cote™ fluoropolymer finishes have a Solar Reflectance Index of 29 or greater.

Roof Systems

MR-24® AND CMR-24® ROOF SYSTEMS



Cool Solar White 22 & 24 ga.



Cool Ivory White 24 ga.



Cool Shell Gray 22 & 24 ga.



Cool Emerald Green 24 ga.



Cool Ocean Blue 24 ga.



Cool Brick Red 24 ga.



Cool Harvest 22 & 24 ga.

VSR II™ ROOF SYSTEM



Cool Solar White 24 ga.



Cool Igloo White 24 ga.

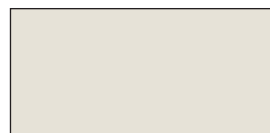

Cool Ivory White 24 ga.

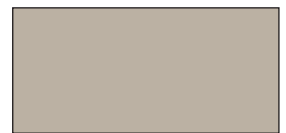

Cool Shell Gray 24 ga.



Cool Country Wheat 24 ga.



Cool Desert Beige 24 ga.

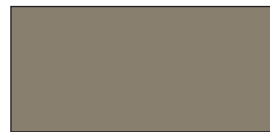

Cool Gray Stone 24 ga.



Cool Marsh Green 24 ga.



Cool Emerald Green 24 ga.



Cool Ocean Blue 24 ga.



Cool Majestic Blue 24 ga.



Cool Brick Red 24 ga.



Cool Harvest 24 ga.

BUTLERIB® II ROOF SYSTEM

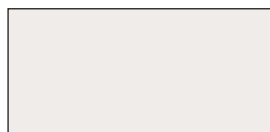

Cool Solar White 24 & 26 ga.



Cool Shell Gray 26 ga.



Cool Emerald Green 26 ga.

MODULEZE™ II SOFFIT COLORS



Cool Solar White 24 ga.



Cool Ivory White 24 ga.



Cool Birch White 24 ga.



Cool Shell Gray 24 ga.



Cool Desert Beige 24 ga.



Cool Harvest 24 ga.

For color, gauges, or color/panel combinations not shown, additional charges apply and a minimum order is required.



Wall Systems

SHADOWWALL™, BUTLERIB® II, STYLWALL® II FLAT AND FLUTED WALL SYSTEMS, AND MOD-36 (GABLE TRIM, EAVE TRIM, GUTTER AND DOWNSPOUTS)



BUTLER THERMAWALL™ WALL SYSTEM



INTERIOR FINISH COLORS (NOT FORMULATED FOR EXTERIOR USE)

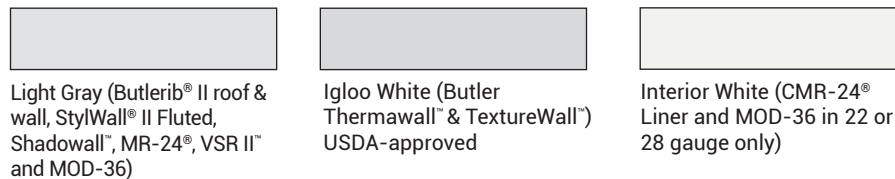

All color selections are close representations, but are limited by processing and viewing conditions.

Lead times may vary by product selection. Contact your Butler Builder® for more information.

GAUGE AVAILABILITY

- Butlerib® II & Shadowwall™ - 26 gauge
- StylWall® II Flat - 26 gauge
- StylWall® II Fluted - 24 gauge
- MOD-36 - 22, 24, 26, and 28 gauge
- Trim - 26 gauge

*Also available in 24 gauge for Butlerib® II, Shadowwall™ and MOD-36

A Commitment to Building Green

All standard Butler-Cote™ 25-year fluoropolymer color finishes feature a Solar Reflectance Index (SRI) of 29 or greater.

Enhance and Protect the Beauty

The standard exterior paint finish for all Butler panels and trim is the Butler-Cote system, consisting of a full strength 70% Kynar 500® or Hylar 5000® PVDF resin-base fluoropolymer finish.

The Butler-Cote system resists the chalking and fading that often leaves a building looking drab

and dated. Our 25-year warranty guarantees that, on roof and wall panel standard colors, chalking will not exceed a rating of #8 and fading will not exceed 5ΔE color difference units. The warranty also covers peeling, cracks, or chipping of the paint finish.

While many manufacturers' warranties are prorated after a certain period of time, we offer our Butler-Cote roof and wall panel warranty for a full 25 years—with no prorating. It's a testament to our high performance standards.

FLUOROPOLYMER FINISH VS. SILICONE POLYESTER AFTER 8 YEARS OF WEATHERING.

	Butler-Cote™ Fluoropolymer Finish	Industry Standard Silicone Polyester Coating
Original Color		
Level of Chalking Allowable Within Warranty Terms		
Warranty Period	25 years	10 years

BUTLER-COTE™ FINISH SYSTEM SOLAR REFLECTANCE DATA			
Available Standard "Cool" Colors	Initial Solar Reflectance	Initial Emittance	Solar Reflectance Index (SRI)
Cool Solar White	0.76	0.84	93
Cool Igloo White	0.64	0.84	76
Cool Ivory White	0.63	0.83	74
Cool Birch White	0.64	0.84	77
Cool Shell Gray	0.55	0.84	63
Cool Country Wheat	0.61	0.84	72
Cool Desert Beige	0.49	0.84	55
Cool Gray Stone	0.37	0.85	39
Cool Marsh Green	0.34	0.85	35
Cool Emerald Green	0.30	0.85	30
Cool Palm Green	0.30	0.84	29
Cool Ocean Blue	0.33	0.84	33
Cool Majestic Blue	0.30	0.84	29
Cool Brick Red	0.34	0.85	35
Cool Harvest	0.32	0.84	32
Cool Onyx Black	0.30	0.84	29
Galvalume® Plus	0.70	0.84	84





Building Systems



Large or Complex Building Designs

For unusually large or complex buildings, Butler Manufacturing™ can save you time and money. We design conventional structural steel with the cost efficiency of Butler engineered building systems. From initial design to finished construction, experienced engineers and project managers can provide a single-source solution to your building needs—working in tandem with your local Butler Builder.®

- Reduced turnkey construction times with the design-build method
- Trusted Butler systems to fit most any building need
- Worldwide network of experienced Butler Builders
- Large clearspan structures—such as sports facilities and aircraft hangars
- Heavy industrial complexes—such as steel mills and paper processing plants
- Highly architectural structures—such as multi-story offices, retail centers, and churches



DREAM BIG. WE BUILD THE IMPOSSIBLE.

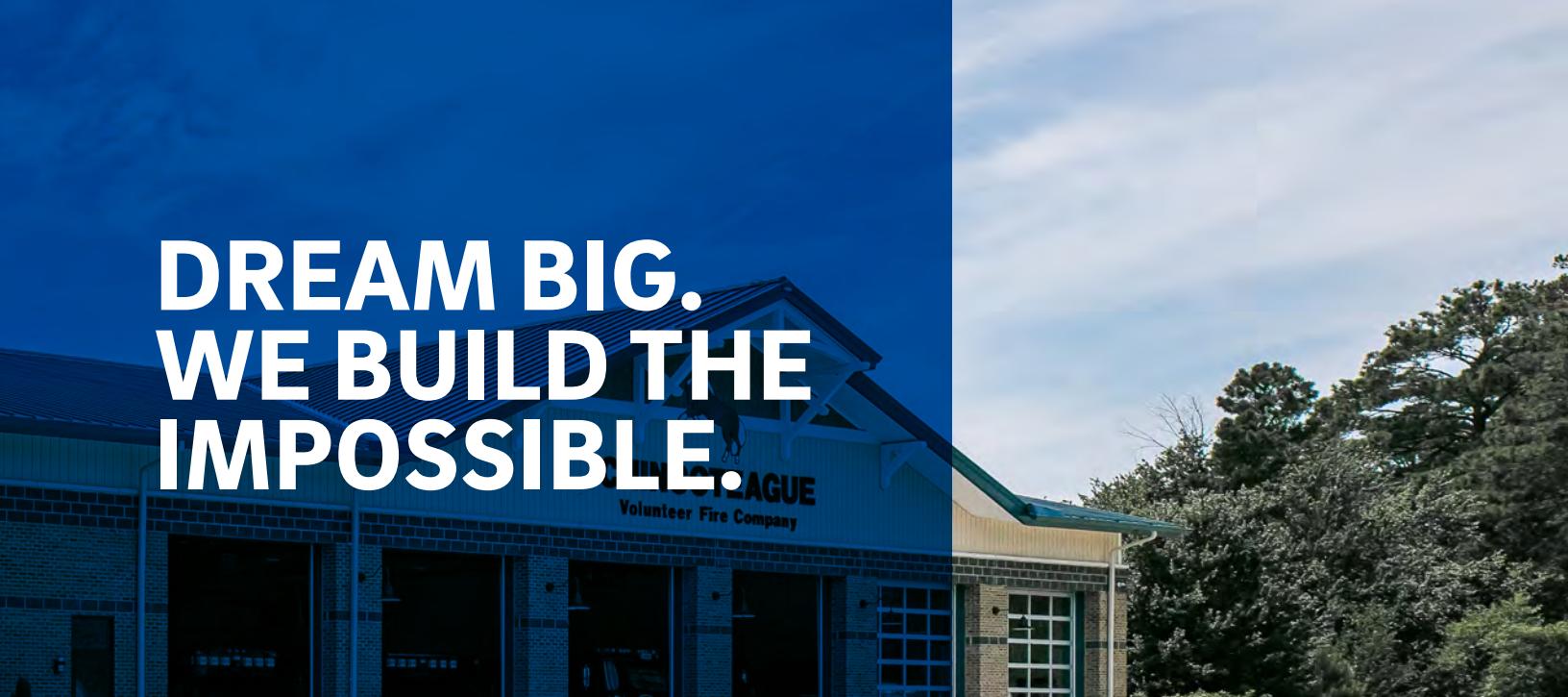

Classic™ Building Systems

The Classic Building System comes in two tiers depending on the delivery you require or the features you have added to the basic structure.

Tier I

These buildings can be delivered in as little as six weeks, with limitations in design. Classic Tier I comes in multiple slopes, widths, and heights with two different wall panels with various color options. You may also choose an array of accessories to make your building more functional and attractive.

Tier II

When your building requires more design flexibility, Classic Tier II gives you a range of options to meet your needs. For example, you can add rooftop units, wainscots, or insulated metal panels (IMPs) to your building to meet your specific requirements.



Self-Storage System

The same high-quality engineering and manufacturing expertise that has made Butler the steel building systems leader goes into each of our self-storage products. These building systems can be designed to fit any width or length in 5-foot increments. Interiors are also designed to be high on flexibility—yet low on maintenance costs.

- A single source for design and construction saves you time and money
- Faster construction gets you open for business and renting units sooner
- Climate-controlled or non-climate-controlled options can be specified
- Available with the industry's #1 standing-seam metal roof—the MR-24® roof system
- Multi-story buildings can be built to meet your specific needs
- Exterior finish options include metal panel, concrete block, tilt-up, or brick





Building Green



A Commitment to Building Green

From material use to transportation costs, construction has an impact on the environment. At Butler, we strive to meet all construction needs with attention to sustainability, providing a more efficient way to complete your construction project. Butler is a member of the U.S. Green Building Council—a testament to our focus on developing responsible building practices.

- Steel is the proven standard in the effort to create sustainable architecture—and Butler® building systems contain a high percentage of recycled steel.
- Butler's factory-produced made-to-order building systems minimize jobsite fabrication and associated waste
- Efficient thermal building envelopes are available to reduce energy consumption
- Regional Butler fabrication plants bring production closer to building sites, reducing transportation energy costs
- The green attributes of Butler can help you earn credits toward LEED® certification



**LEED Silver Certified:
University of Connecticut,
Mark R. Shenkman
Training Center**



CREATING SUSTAINABLE ARCHITECTURE

“Cool Roof” Finishes

Butler offers a full palette of fluoropolymer color finishes that meet reflectance and emittance standards for “cool roofs” as established by energy codes. These 25-year finishes have a Solar Reflectance Index (SRI) as high as 91.

Butler “cool roofs” help reduce the Heat Island Effect which produces high relative temperatures in urban areas. In this way, Butler building systems help ensure a safer habitat and climate.

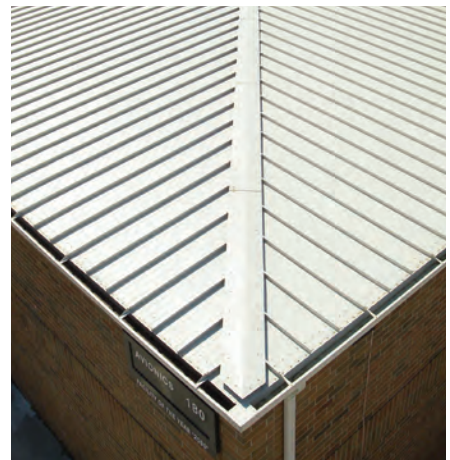

Butler-Cote™ - A Sustainable Finish System

Butler's sustainable Butler-Cote™ premium finish is the standard exterior finish on all painted panels and trim. It features high reflectivity to help lower energy consumption and meets or exceeds EPA regulations for low-VOC paints. This incredibly durable Kynar 500® or Hylar 5000® system is the finest factory-applied finish in the industry, resisting fading and chalking to remain vibrant for years. Many attractive standard color options are available with a Solar Reflectance Index (SRI) of 29 or greater.

While many manufacturers' warranties are prorated after a certain period of time, we offer our Butler-Cote roof and wall panel warranty for a full 25 years—with no prorating. The 25-year warranty also protects against blistering, peeling, cracking, or chipping of the paint coating. It's a testament to our high performance standards.



Build With Confidence



Innovation -The Butler Research Center

Demonstrating Butler's commitment to excellence, the Butler Research Center has led the industry in product development and innovation since 1959. The Butler Research Center is the most comprehensive facility of its kind, conducting ongoing tests of Butler's current materials and products to ensure continual, evolutionary improvements of Butler® building systems.

- All structural steel, panel materials, bolts, fasteners, and sealants are subjected to rigorous quality control
- The strength of components and systems is studied with a variety of full-scale tests
- Panel finishes are tested for qualities such as weathering, adhesion, color match, gloss, hardness, and a variety of performance characteristics in virtually any environment

Thermal Performance Testing

In the early 1970's, Butler constructed one of the first Guarded Hot Boxes in North America for the in-place performance testing of U-factors for roof, wall and insulation system assemblies. Today, Butler has expanded this program by constructing a state-of-the-art Guarded Hot Box to develop and test new assemblies which meet new stringent building codes while saving energy and money.



The IAS accredited Butler Guarded Hot Box is a state-of-the-art design that can accommodate 8'x 10' roof or wall sections fitted with up to 300 sensors to accurately measure temperature, humidity and air flow.



OVER 1,000 WORLDWIDE CERTIFIED ERECTORS



An Erector You can Trust!

No aspect of constructing your new Butler® Building is more important than the erection process. Today, there are more than 1,000 certified Butler Erectors worldwide, representing the largest network of construction professionals in the world. Metal Building Sales® connects Certified Butler® Erectors with builders like you.



- Independent construction professionals who undergo comprehensive training from Butler Manufacturing®
- Single-source responsibility assures faster construction and greater cost effectiveness
- Local businesspeople with outstanding reputations in their communities

Design Integrity

Butler Manufacturing is an IAS-accredited metal building manufacturer. The IAS accreditation program recognizes manufacturers who design and fabricate safe, high-quality structures. It assures quality and consistency in metal building manufacturing.

The rigorous certification process scrutinizes all of the things that are important to you in selecting a manufacturer, including raw material purchasing, welding practices, material receiving, quality control measures, and overall fabrication quality assurance. As a buyer, you should always specify an IAS-accredited fabricator and require a copy of the accreditation certificate. It's your symbol of quality assurance.



Butler also maintains the high-quality design standards required as a member of the Metal Building Manufacturers Association.

Metal Building Sales®

Metal Building Sales®—offers turn-key construction services with a single-source of responsibility. Find us at:

www.MetalBuildingSales.com.

High-performance products—such as acrylic-coated galvanized C/Z purlins and girts, and structural and wall systems that integrate easily with conventional building materials.

Butler-Cote™ finish—only Butler offers this superior full-strength Kynar 500® or Hylar 5000® Fluoropolymer finish system as the standard exterior finish on all painted panels and trim.



Metal Building Sales
2315 South Bascom Avenue, Suite 200
Campbell, CA 95008

408.691.6002

WWW.METALBUILDINGSALES.COM

Galvalume® is a registered trademark of BIEC International Inc. Kynar 500® is a registered trademark of Arkema. Hylar 5000® is a registered trademark of Solvay Solexis. Thermax™ is a trademark of The Dow Chemical Company. ("DOW") or an affiliated company of DOW. LEED is a trademark of the U.S. Green Building Council. The USGBC logo is a registered trademark owned by the U.S. Green Building Council and is used by permission.

© 2022 BlueScope Buildings North America, Inc. All rights reserved. Butler Manufacturing™ is a division of BlueScope Buildings North America

